

NOVA[®]
The Right Solutions



Downward Gaze Angle™
Computer Workstation Handbook



Introduction	3	Eyeglasses	
Ergonomics	3	Ergonomic Seating	15
Why is Ergonomics Important?		The Importance of Ergonomic Seating	
Cumulative Trauma Disorders:		Footrests	
A Growing Epidemic		Lighting	16
Who's at Risk for Cumulative		Screen Colors	
Trauma Disorders?		How to Solve Reflection Problems	
Standards		How Nova Reduces Glare and Reflection	
The Costs of Bad Ergonomics		with Contrast Enhancement	
Cumulative Trauma Disorders	4	CDAR Anti-Reflective Coating	
Trauma Disorders		Thermoformed Visor	
Carpal Tunnel Syndrome		Monitor Placement	
The Risk Factors for CTDs		Tackle Lighting Problems Early	
Repetition		Installation	18
Excessive Force		How to Adjust your Monitor	
Awkward Posture		Nova - Beyond Ergonomics	19
Rest and Recovery		References	19
Exercises			
Nova and Your Eyes	8		
Why Nova Solves Problems			
Accommodation			
Accommodation and Distance			
How Viewing Angle Affects Our Eyes'			
Ability to Accommodate			
Vergence			
Vergence and Distance			
How Viewing Angles Affect Our Eyes'			
Ability to Converge			
Limitations on Maximum Viewing Distance			
A Shorter Viewing Distance			
Eye-to-Screen and Hard Copy Distances			
Dry Eyes			
Vision and Posture Interact			
Vision and Posture Problems with			
Eye-level VDTs			
Required and Voluntary Movements			
Neck Postures with Nova			
Monitor Tilts			
Computer Users Prefer Greater Distances			
and Lower Viewing Angles			

If we were wooden puppets, we wouldn't worry about the ergonomic design of a workstation. Our bodies could adapt to any position without risk of injury. But we're not puppets. Our bodies have a natural way of seeing and moving. When we go against nature, we set ourselves up for injury.

What is remarkable about the Nova concept is that it allows your body to work in a natural way. Your eyes have a natural viewing angle for near work, the same angle you use when reading a book. Nova allows you to view your screen at that same angle.

Nova integrates the viewing angles and distances supported by studies in the fields of ergonomics and optometry. Nova positions the computer 30 inches or more from the eye and 20-40 degrees below horizontal eye level.

Ergonomics

Why Is Ergonomics Important?

Ergonomics studies the relationship between workers and their environments. The ergonomist modifies environments to fit the capabilities of workers.

Ergonomic solutions increase productivity and job satisfaction and result in fewer injuries to workers.

Traditional workplace design followed the flow of materials with little or no regard for the safety or health of the work force. If, after a few years, you developed backaches or stiff joints, a physician might have diagnosed it as arthritis or "just old age."

Cumulative Trauma Disorders: A Growing Epidemic

In recent years, a new category of disease has been recognized: Cumulative Trauma Disorders (CTDs). There are several terms used for CTDs, including Repetitive Motion Injury (RMI), Repetitive Strain Injury (RSI), Work Related Musculoskeletal Disorder (WRMD), and Occupational Overuse Syndrome (OOS). CTDs result from repeating the same or similar motions over and over again. Awkward posture, force and lack of adequate recovery time increase one's chances for developing CTDs.

Just what is a Cumulative Trauma Disorder? A trauma is a shock to the body. A painter breaks an arm after falling from a ladder. We can easily identify the cause of that "disorder" - a fall. The injury was not cumulative; it resulted from a single incident.

CTDs, however, do not result from a single event. They result from the accumulation of small shocks to the body.

Strike the letter "a" on your keyboard. That single, small shock to your hand and wrist looks and feels harmless. It is. Increase that action to 20,000 times a day with poor wrist posture. Over a period of time, the result could be a CTD such as Carpal Tunnel Syndrome.

The U.S. Department of Labor (Bureau of Labor Statistics: (202-606-7800) reports that over a period of 11 years, CTD (CTDs include, among others, Carpal Tunnel Syndrome, Tension Neck Syndrome, Tenosynovitis, Trigger Finger, Epicondylitis, and Rotator Cuff Syndrome) cases grew from 18 to 61 percent of all reported occupational disease cases. Although industrial work remains the greatest risk for CTDs, computer workers report more and more problems.

Carpal Tunnel Syndrome, back and neck pain, and visual complaints top the list of concerns. Because computer use is relatively new to the office, it has been impossible to predict the long-term effects of keying.

Who's at Risk for Cumulative Trauma Disorders?

When scientists study the cause of diseases, one of the first questions they ask is, "Who is at risk?" The National Association of Working Women estimates that over 50 million computer workstations exist in offices across the country. That's two computers for every three white-collar workers.

Census Bureau statistics show that 52 percent of women and 40 percent of men used VDTs on their jobs in 1993. Not everyone who uses a computer is at risk for developing a CTD. But studies show that computer users complain more about eyestrain, neck aches and backaches than workers in similar jobs without computers.

While no precise formulas can dictate just how much computer work it takes to develop a CTD, many positive steps can be taken to reduce the risk of developing these disorders.

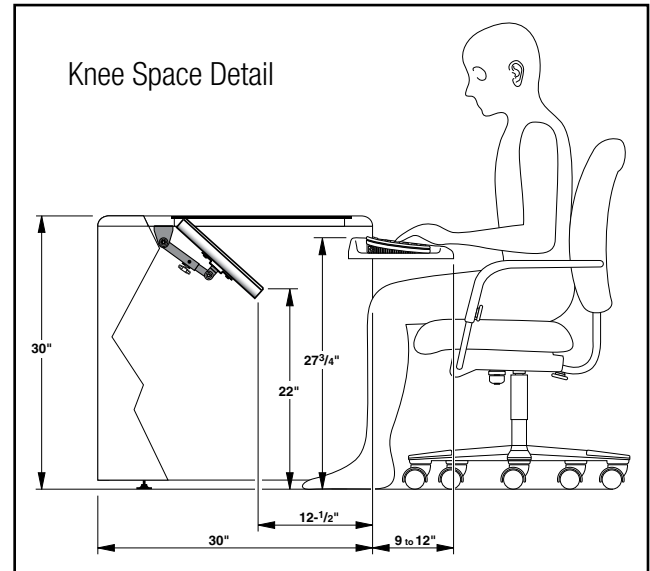

Standards

In response to the concerns of computer users and others, governmental bodies have passed laws regulating computer workstation use. The International Standards Organization has issued a standard for computer workstations, ISO-9241. The American National Standard for Human Factors Engineering of Visual Display Terminal Workstations (ANSI HFS-100 1988) outlines specific standards for creating a safe computer workstation.

The ANSI committee is rewriting the current standard to reflect the latest knowledge about seating posture, workstation design, keyboards, monitor/VDT height and more.

The Cost of Bad Ergonomics

Workers' compensation costs have become outrageous. According to John Burton's *Workers' Compensation*, workers' compensation costs rose from \$2.1 billion in 1960 to \$62 billion in 1992. The average for one midwestern state government was \$8,980 per CTD. Each CTD can cost thousands of dollars in lost productivity, absenteeism, medical treatment and, in some cases, surgery. Although at present, the vast majority of these claims come from industries such as meat packing, computer workstation injuries are growing rapidly.

The aches and pains caused by ergonomically inferior workstations lead to trips to doctors and chiropractors. This raises health insurance costs and increases absenteeism. That's not counting the cost of acquiring and training new workers.

CTDs can develop over a short or long period of time. One goal of ergonomics is to identify risk factors and reduce them before they cause damage. If companies don't address CTD risk, both in industry and in the office, the costs will be devastating.

Good ergonomics, however can make a company money. In laboratory tests, Dainoff (1986) discovered an average increase in productivity of 24.7 percent with ergonomically optimal computer workstations.

The Development of Cumulative Trauma Disorders

Cumulative Trauma Disorders don't occur all at once. That's why they're called "cumulative." CTDs result from continuing small traumas, or shocks, to the soft tissues of the body.

CTDs develop in the following three stages (Chatterjee 1987, cited in Kroemer 1989):

Stage 1 - In the first stage, workers experience aches and tiredness during working hours. The symptoms usually disappear overnight and on days off. Work performance usually stays the same.

Stage 2 - In this stage, the symptoms start early in the work-shift and do not go away overnight. Workers may have difficulty sleeping and work performance declines. This stage usually lasts for months.

Stage 3 - By the time workers get to stage three, the pain persists at rest and even with non-repetitive movements. Sleep becomes more disturbed. Workers can't perform even light duties without pain. They have problems doing other tasks. Stage may last for years.

If treated in the first stage, the problem can be reversed. By the third stage, medical attention is necessary.

A new job or routine often requires the use of new muscles. That alone can cause aches and pains. But this "work hardening" usually lasts only a few days.

If a task isn't new and a worker recognizes the symptoms of stage one, it is crucial that he or she report it immediately. Ergonomic solutions can prevent the problem from reaching stage two.

Too often, workers don't report aches and pains. Some fear being labeled as complainers; some fear being fired. A work climate that discourages workers from reporting possible CTDs can force the symptoms into stage 3 before medical attention is sought.

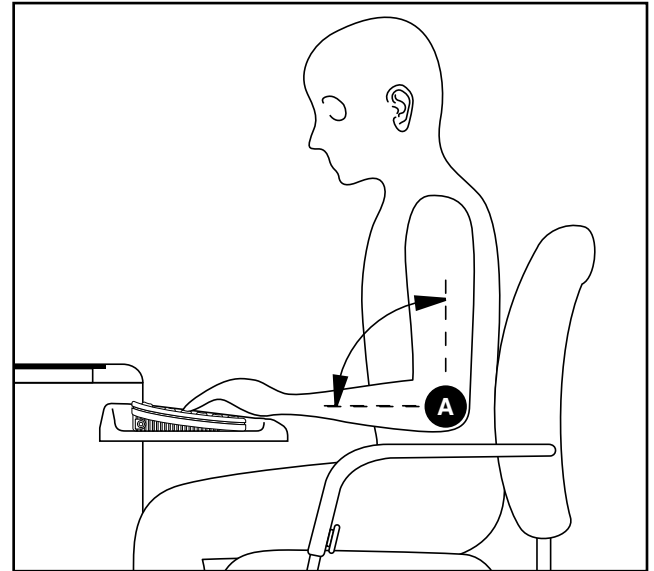

The Cumulative Trauma Disorder getting the most attention in the media is Carpal Tunnel Syndrome (CTS). Our hands and wrists are comprised of various bones, tendons, nerves, muscles and ligaments. The center of the wrist contains a small tunnel called the carpal tunnel. That tunnel is formed by the carpal bones and a thick ligament called the flexor retinaculum (Anderson 1987).

CTS develops when the tendons inside the carpal tunnel swell up. They put excessive pressure on the median nerve. (The median nerve transmits sensory and motor signals to and from part of the thumb and first three fingers.)

CTS sufferers often feel a pain, numbness and a tingling in their hand(s), particularly in the evening or early morning. They have trouble gripping, and frequently drop things.

Treatment can be as mild as a wrist splint, but often requires expensive surgery to relieve the pressure on the median nerve. Unless the conditions that originally caused the problem are changed, CTS is likely to recur.

Don't assume that pain in your wrist or hand comes from a problem in the carpal tunnel. The median nerve can also be entrapped in the elbow and in the shoulder. Because a syndrome is by definition a collection of symptoms, problems which do not originate in the carpal tunnel are often labeled as Carpal Tunnel Syndrome. This can lead to inappropriate surgery.

Some CTS operations fail simply because the patient did not have a problem in the carpal tunnel in the first place. A nerve conduction velocity test must be done before even considering surgery.

After surgery, many computer users expect to return to the same work. If the job is not modified substantially, the problem will reappear. It's like having a collision with a brick wall. Do you get your car out of the body shop and aim it toward the same brick wall?

Risk Factors for CTDs

Four physical risk factors (other risk factors, not usually found in offices, include cold and vibration) act together at the keyboard:

1. Repetition
2. Excessive Force
3. Awkward and/or Sustained Postures
4. Lack of Adequate Rest/Recovery

The more a job exposes a computer user to the above conditions, the greater the chance of fatigue, or wear and tear on nerves, muscles and tendons.

One goal of ergonomic design is to reduce risk factors as much as possible.

Repetition

No one should key constantly for eight hours a day. CTDs were not as common with typewriter use because a typist's hands rest more than a computer user's. A typist returns carriages, changes paper and ribbons and uses correction fluid or tape.

Excessive Force

Many computer users key with a much harder touch than necessary. Most keyboards need only light pressure to respond. A soft touch reduces the impact on your fingers.

Excessive Force - Cont'

Try this challenging exercise. (It's not as easy as it appears.) Practice keying with such a light pressure that no characters appear on the screen. Now increase the pressure just enough so that letters do appear. This is the most pressure you should use.

When you use more than the minimum pressure needed, you increase your risk of injury.

Awkward Posture

Prolonged sitting stresses our bodies. Sitting contracts muscles. That requires energy, just like dynamic activity does. But with dynamic work, our muscles contract and expand. That action removes waste and pumps new nutrients to the cells. Without movement, lactic acid builds up and causes fatigue.

When we move and shift our posture, our blood flow increases. Movement also distributes the weight to different parts of the body.

Rest and Recovery

Rest breaks and alternative work let the body recover from computer work. It's better to take several short breaks than one long one. In an alternative work break, a computer operator performs non-computer tasks.

Exercises

Even with the best ergonomic furniture, VDT work involves constrained postures. To reduce this risk factor, many ergonomic guidelines suggest exercises.

You should use extreme caution when choosing exercises.

In a review of 127 recommended exercises, a study found that 90 percent of those exercises could cause problems for individuals with one or more acute or chronic musculoskeletal disorders (Lee et al. 1992). Forty percent of the exercises reproduced or exacerbated some of the physical or biomechanical demands of the job.

Exercises should not stretch already over-stretched muscles. A good exercise program has the following components (Adapted from Lee, et al, 1992):

1. Stretching of shortened and tensed muscles. This improves flexibility and circulation and reduces muscle fatigue.
2. Contracting or strengthening stretched and weakened muscles. This increases resistance to fatigue and discomfort, and promotes better posture.
3. Movement of the spine. This relieves stress on lower back muscles and reduces the compression of intervertebral discs.
4. Improvement of blood return from the legs.

Computer users have been known to continue exercises even though they cause pain. They assume that an exercise manual would not prescribe something harmful.

If An Exercise Causes Intense Pain, Stop Doing It!

Consult a medical professional if you experience pain or have any questions about the effects of exercises.

Why Nova Solves Problems

Why does Nova put the monitor below the horizontal line of sight? Because that position conforms to the way our eyes work.

Our “normal line of sight” varies with our viewing distance. When we look at objects far away, our eyes are most comfortable viewing them straight ahead, i.e. horizontally. On the other hand, we strain our eyes less when we view close objects at lower angles.

Most objects high in our line of sight are at far distances, such as the horizon. Objects that are lower in our line of sight are almost always closer. This is most noticeable outdoors.

Vision complaints rank high on the list of computer user problems. One study found that more than 50 percent of computer users suffered eye strain after an eight hour shift (Gunnarsson and Soderberg 1979).

Two causes of eye strain are the stresses on accommodation and convergence (Fischer 1977, Collins 1975). When we look downward, our eyes more easily accommodate and converge.

- A. Eye-to-screen distance: 30” or more from the eyes
- B. About 35° (depending on user’s height)
- C. About 25° (depending on neck angle and user’s eye height)

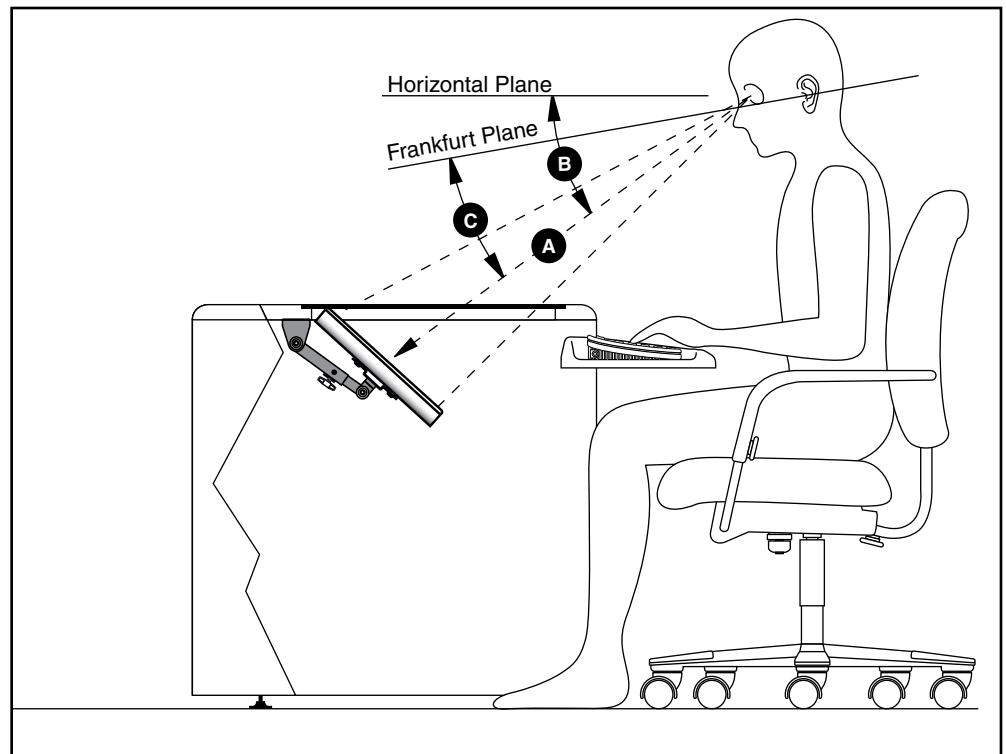

Accommodation

When we look back and forth between objects at different distances, the ciliary muscle in the eye changes the shape of the lens capsule (Kaufman 1992). The light rays bend so that they strike the retina at a single point. This allows a sharp image to be interpreted by the brain.

If that point is too far in front of or behind the retina, blur results. In reaction to that blur, the brain causes the ciliary muscle to change the shape of the lens capsule. That brings the object into focus. The closer the object, the more the lens must accommodate.

Accommodation and Distance

When our eyes relax and have nothing specific to look at, they automatically focus at a distance called the resting point of accommodation.

Not so long ago, scientists believed that the resting point of accommodation was infinity. They recommended that we “look off into the distance” to relax our eyes. Recent studies show that the resting point of accommodation is not infinity. It's much closer (Owens 1984). While it differs among individuals, it averages about 31 1/2 inches (Krueger 1984).

When you work at distances closer than your resting point of accommodation, your ciliary muscle must work harder to focus. This contributes to eye strain, (Jaschinski-Kruza 1988). The closer the object, the greater the strain. The ciliary muscle must work two-and-a-half times harder to focus on a monitor 12 inches away than it does to focus on one at 30 inches (Fisher 1977).

Your Eyes Improve Their Ability To Accommodate Simply By Looking Downward.

How Viewing Angle Affects Our Eyes' Ability to Accommodate

When we change our viewing angle, we also change our eyes' ability to accommodate. Ripple (1952) found that subjects over age 42 increased their ability to accommodate by an average of 25 1/2 percent by directing their eyes down in the “usual reading position.” The improvement for younger subjects was even greater.

Try this for yourself: Hold a business card with text on it at arm's length in front of your eyes. Bring it toward you until the letters just begin to blur. Without moving your head, gradually lower the card in an arc, keeping it the same distance from your eyes. You should notice the letters getting sharper.

Your eyes have improved their ability to accommodate simply by looking downward.

Vergence

As we look at close objects, our eye muscles move our eyes inward toward the nose. This convergence lets the eyes project the light from both objects to the same relative place on the retina of each eye. If we didn't have accurate convergence, we would see double images (Tychsen 1992).

Vergence and Distance

Our eyes also have a resting point of vergence. This varies among individuals, but averages around 45 inches when looking straight ahead (Heuer 1989). Strain on the muscles controlling eye movements occurs when we view objects closer than the resting point. The closer the distance, the greater the strain.

Two studies have shown that the resting point of vergence has an even greater impact on eyestrain than the resting point of accommodation.

In the first study, Jaschinski-Kruza (1988) divided subjects into two groups: near and far.

The first (near) group had resting points of accommodation of around 20 inches. The second (far) group's resting points of accommodation averaged 40 inches.

Both groups worked on computers at viewing distances of 20 inches and 40 inches. As expected, the near group had less eyestrain working at 20 inches than the far group. But both the near and far groups had less eyestrain at the 40-inch distance. Both groups judged the 20-inch monitor distance as "too near," and both groups accepted the 40-inch distance.

When Jaschinski-Kruza measured productivity, he found that both groups had greater productivity at the 40-inch distance.

Although their resting points of accommodation were different, both groups had far resting points of vergence. Jaschinski-Kruza concluded that increased convergence seems to be crucial in causing visual strain.

Owens and Wolf-Kelly (1987) found that after one hour of near work, the resting points of both accommodation and vergence shifted inward toward the eyes. The amount of the shifts depended on the positions before the near work: Subjects who began the tests with far resting points had the greatest inward shifts.

They found that the greater the decrease in the resting point of accommodation, the greater the reduction in visual acuity, or keenness, at distance. Changes in the resting point of accommodation did not correlate with subjective eye fatigue.

On the other hand, greater inward shifts in the resting point of vergence were associated with greater eye fatigue, but not with changes in visual acuity.

The more you work at close distances, the more your eyes try to adapt by bringing your resting points closer.

This inward movement of the resting point of vergence could be the visual system's reaction to fatigue.

How Viewing Angle Affects Our Eyes' Ability to Converge

The eye muscles require less effort to converge when looking down and to diverge when looking up (Bielschowsky 1940). As Krinsky (1948) wrote, "When looking upwards, the eyes tend to diverge...and when they look down, the effort to converge is much easier."

The resting point of vergence changes with gaze angle (Heuer 1989). The lower the gaze angle, the closer the resting point of vergence.

With a 30-degree upward gaze angle, the unstimulated eyes converge on a target about 53 inches away. Looking horizontally, as you would with an eye-level monitor, the resting point of vergence distance is about 45 inches.

When looking down 30 degrees, the resting point equals about 35 inches of viewing distance. Looking down 40 degrees brings the resting point of vergence in to about 32 inches.

Not everyone changes their resting point of vergence when looking up and down. But for those who do, a downward gaze reduces headaches and eyestrain (Tyrrell 1990).

Limitations on Maximum Viewing Distance

Some guidelines have set limitation on maximum viewing distance. In reality, the only limit to viewing distance is your ability to read the screen. In general the farther away your monitor is from your eyes, the better. But once you have moved it out to your resting point of vergence, moving it farther away will not produce any additional benefits (Ankrum 1996).

A Shorter Viewing Distance

With a conventional workstation, it's difficult to get the monitor far enough away to be beyond the horizontal resting point of vergence (about 45 inches on average). That is because of the depth of most work surfaces.

If we can't move the monitor farther away, lowering it has the same effect on our eyes. When we lower the gaze angle, we bring both resting points inward. That allows the same distance in inches to be less stressful.

Eye-to-Screen and Hard Copy Distances

For years, computer users were advised to place hard copy and the monitor at the same distance to reduce eye strain. A recent study found no basis for this recommendation. Jaschinski-Kruza (1990) found no increased eye strain when the distances differed between screen and document. In fact, users preferred the screen at a greater distance than the hard copy.

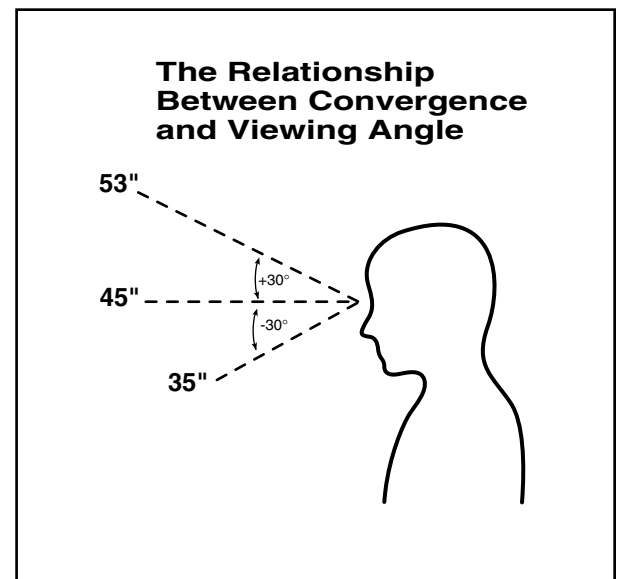

Dry Eyes

A thin layer of tears covers the surface of the eye. This later dries out when exposed to the air. When we blink, our eyelids spread a new tear layer.

Looking straight ahead or up at a monitor exposes more of our eye's surface than when we look downward. A letter to the New England Journal of Medicine reported a study on tear evaporation (Tsubota 1993).

Researchers found that tears evaporate at a faster rate when we gaze straight ahead at a monitor than when we look downward in a natural reading position.

The authors found that subjects blinked less and had an increased rate of tear evaporation when using a VDT than under relaxed conditions.

Our eyelids partially close when we look downward. That reduces the surface of the eyeball exposed to the atmosphere. It also helps counteract the effects of reduced blinking.

The researchers suggest that computer users lower the monitor and tilt the screen upward.

Their report confirms a 1987 unpublished study by the late Bruce Rupp (1987) of IBM. Rupp found that when subjects looked downward at a 45-degree angle, they exposed over 40 percent less of the eyeball's surface than when they looked straight ahead.

In addition to reducing the exposed surface, a downward gaze angle also increases the volume of tears our eyes produce (Sotoyama et al. 1997). So not only does a downward gaze angle cause the tears to evaporate more slowly, there are more of them produced.

Mean Rate of Blinking

measured 22.5° C and 40% humidity

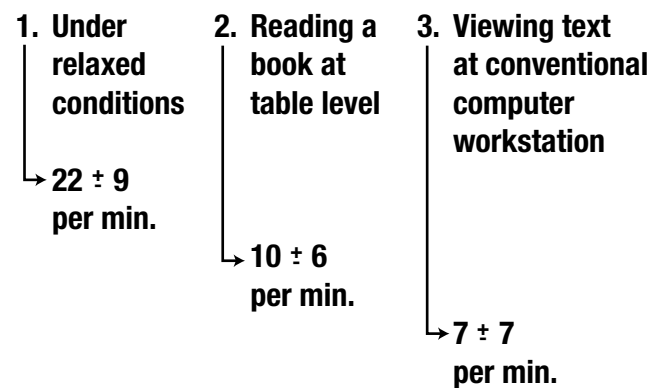

Vision and Posture Interact

The location of the monitor often determines the range of comfortable postures we can assume. Sometimes we are forced to strike a balance between postural and visual comfort.

For example, if the monitor is to our left or right, we will most likely twist our necks and/or trunks into uncomfortable positions in order to see clearly.

Vision and Posture Problems with Eye-level VDTs

In the past, some VDT guidelines recommended placing the top of the monitor at or slightly below eye-level. The reasons for that included reducing the load on the neck muscles by preventing the user from tilting the head too far back or forward. That attempt to encourage a neutral posture can actually produce the opposite results. As Ankrum and Nemeth (1995) explain, the eye level monitor position, when combined with an upright trunk posture, restricts the range of comfortable head and neck postures a user can assume.

When the head-erect posture becomes tiring with an eye-level monitor, we have three alternative neck postures we can assume.

One option is to tilt our heads back. That posture increases muscular tension in the neck and back muscles.

The second option is what is called the “forward head posture.” Keeping our head erect, we jut it forward from the trunk. With that position, we attempt to relieve muscle tension from contracted neck muscles. Unfortunately, that posture is associated with cervical headaches, increased fatigue and thoracic outlet syndrome.

The third option with an eye level monitor is bending the neck forward (flexion). Chaffin (1973) found that sustained neck flexion of 15 degrees caused no subjective discomfort or EMG changes after six hours with ten-minute breaks each hour.

While neck flexion may be comfortable, try bending your neck down and looking out of the top of your eyes at something close. Because it's not comfortable on the eyes, most people refuse to do it.

The net result is that eye-level monitors allow for only one healthy head/neck posture. When you get tired of maintaining that posture, the alternative positions are unhealthy.

Eye level has often been determined with the user “sitting tall.” But is this the way we usually sit? In normal upright sitting (without a visual target), subjects studied by Hsiao and Keyserling (1991) tilted their heads an average of 13 degrees forward from the “upright” position. In fact, hardly anyone sits in the “upright” posture often shown in some guidelines.

If the monitor is set to eye level as described in the preceding paragraph, the user is presented with a choice: either assume a more erect head/neck posture than preferred, or look up at the monitor. Most people find it uncomfortable to look out of the top of their eyes at something close.

Required and Voluntary Movements

The ability to move is important for comfort. Movement reduces static loads and increases blood circulation. There is a difference between required and voluntary movement (Ankrum and Nemeth, 1995).

Required movement is movement that a task requires us to do, such as having to shift the head between the screen and printed materials. Voluntary movements are postural changes that are allowed, but not required by the task. We want to minimize required movements, but we want to encourage voluntary movements.

Neck Posture with Nova

Nova's monitor placement allows a wide range of voluntary neck postures with a minimum of postural and visual discomfort.

With Nova's lower monitor position, you can hold your head erect and direct your eyes downward. When that posture becomes tiring (as eventually it will), you can bend your neck downward in a wide range of comfortable neck postures. These temporary changes of neck posture can relieve neck strain with little or no visual discomfort.

In guidelines for workplace and machine control layout, Chaffin (1991) considered a head inclination of 20 to 30 degrees as normal.

Monitor Tilts

A study by Ankrum, Hansen, and Nemeth (1995) shows that the angle at which the monitor is tilted plays a role in discomfort. When we read a magazine, we naturally hold it so that the top is farther from the eyes than the bottom. That conforms to the way our visual system has developed since infancy. Almost anywhere we look, what is below the object we are looking at is closer to our eyes than what is above the object we are looking at. Our visual system has developed different abilities based on the environment it developed in.

They found that neck, upper back and visual discomfort increased when the monitor was tilted down so that the top was closer to the eyes than the bottom. Nova allows a monitor tilt that conforms to the way your visual system has developed.

Computer Users Prefer Greater Distances and Lower Viewing Angles

What computer users prefer agrees with the physiological findings.

In the Jaschinski-Kruza (1988) study mentioned earlier, all subjects judged an eye to screen distance of 20 inches as being too close, and all accepted a 40-inch distance.

Hill and Kroemer (1986) found that the closer the object, the lower the preferred viewing angle. With a target 40 inches away, the preferred viewing angle was -30 degrees below the Frankfurt Plane. The Frankfurt Plane is an imaginary reference plane passing from the center of the ear hole through the bottom of the eyeball socket. When the head tilts forward, the Frankfurt Plane tilts with it.

At 20 inches, the downward preference increased to -38 degrees. With a normal computer-work posture, the average preferred viewing angle was -29 degrees below the Frankfurt Plane.

The subjects were not permitted to move their heads during these tests, so the downward gaze resulted solely from movement of their eyes.

Eyeglasses

A survey by Sheedy (1992) estimated that 14.25 percent of optometric patients had symptoms primarily associated with VDT use. This means that out of the 75 million eye exams given each year in the United States, over 10 1/2 million address VDT problems.

Since VDT work puts high demands on the visual system, minor visual disorders which could go unnoticed in other types of work will cause symptoms in a computer user.

Eyeglasses

A survey by Sheedy (1992) estimated that 14.25 percent of optometric patients had symptoms primarily associated with VDT use. This means that out of the 75 million eye exams given each year in the United States, over 10 1/2 million address VDT problems.

Since VDT work puts high demands on the visual system, minor visual disorders which could go unnoticed in other types of work will cause symptoms in a computer user.

Before visiting an optometrist, take measurements of your eye to screen distance, your eye to hard copy distance, and the angle at which you view the screen. Draw a picture to show the placement of windows and other light sources.

Your optometrist can then prescribe lenses tailored to your work environment. A good resource for optometrists is "Video Display Terminals, Solving the Vision Problems" by Sheedy (1990).

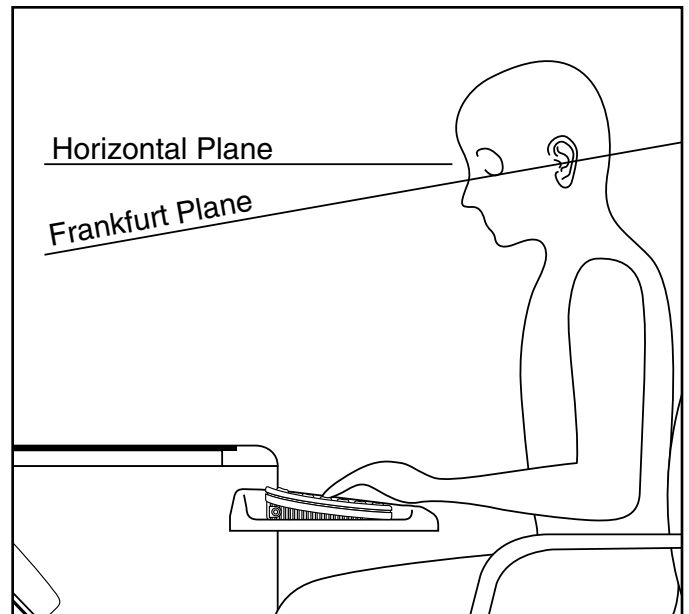

Ergonomic Seating

The Importance of Ergonomic Seating

To take full advantage of Nova's benefits, you must use an ergonomic chair.

Ergonomic chairs adjust to encourage good postures and to allow a flat wrist position. They encourage movement and provide many other benefits.

Before you make a decision, consult a seating guide.

Footrests

If, after adjusting your chair height to achieve a flat wrist position, your feet don't rest comfortably on the floor, you need a footrest.

Make sure the footrest is heavy enough to be stable. Both feet should fit on the platform with space between them. Height and angle adjustments allow shorter users to maintain a comfortable thigh angle while keeping their feet flat. Some footrests move. This promotes blood circulation.

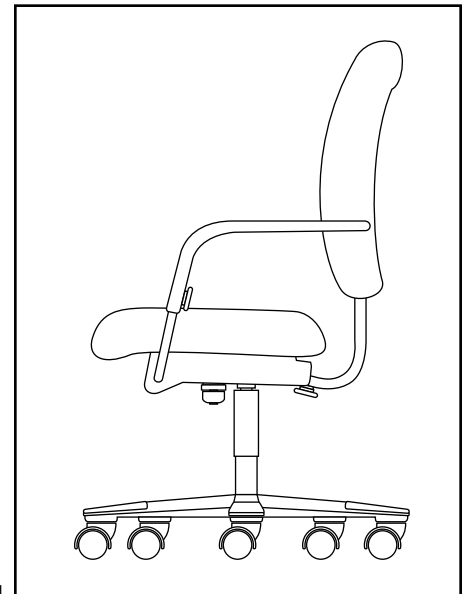

Ceiling suspended, indirect lighting. Control outside light with blinds and shades.

Good office lighting provides adequate light levels for all tasks performed in the office. It should reduce or eliminate glare and reflections. In an office of any size, the best solution to glare and reflections on the screen is ceiling suspended, indirect lighting. This is sometimes referred to as “uplighting.” The underside of the lamps should be the same color as the ceiling. Wall mounted scones may also be appropriate in certain instances.

Understanding a little bit about the principles of lighting can help you improve just about any office environment. First we have to understand what we are trying to accomplish. When evaluating a monitor, high contrast is desirable. You want the letters to stand out from the background.

When evaluating what is reflected from the screen, it is the opposite: contrast is the enemy. Contrast reflected into the screen competes for the user’s attention with the contrast on the screen. In some cases this can be an irritation, but in others it can make sections of the screen impossible to read.

Aside from absolute brightness, the main problem with direct ceiling lights is that they provide a high contrast with the rest of the ceiling. Many guidelines mistakenly specify a luminance (brightness) value for ceilings and walls. While absolute intensity is important (a bright light reflecting off the screen will always cause problems), the contrast is much more critical. Interrupting the ceiling with patches of bright light almost guarantees competing reflections in the screen.

What can you do if you have computers, but can’t install indirect lighting?

With small office areas, it may be possible to reposition desks, or remove or shade individual glare sources. However, this can become unwieldy for large areas. Repositioning a lamp may just transfer the problem to another workstation.

In many instances it is possible to retrofit deep cell small cube parabolic or paracube lenses to replace other types of lenses. If the cutoff angle (the angle beyond which the bulb cannot be seen) is acceptable, reflections of the light source from the screen will be eliminated. In other instances it may be possible to install shields or screens to reduce or eliminate the reflected contrast. Reorienting the screen can help in some instances. But, as we saw earlier, it should not be tipped down. Hoods can be effective, as can removing bulbs. Task lights can supplement lower levels of ambient lighting. Remember, because the front of the screen is glass, **something** is going to be reflected from it. The goal is to reduce the contrast in those reflections.

New monitors should have anti-reflective screen coatings. You can apply these coatings to older monitors. Rea (1991) offers an excellent discussion of VDT lighting.

Screen Colors

Screen colors: dark letters on a light background.

With the monitor off, look at your reflection in the screen. Now turn the monitor on and select a Windows type background, (black letters on a white background). Notice how you cannot see your reflection as well.

Contrast is simply the difference in brightness between two images. With a white background, we reduce the difference in contrast between the screen and what is reflected off of it.

Negative screen contrast (black letters/white background) can reduce reflected images, as we saw with the demonstration. A white background also reduces the luminance (brightness) difference between the screen and the surrounding background of a normally lighted office. Snyder, et al. (1990) found performance increases, and Bauer and Cavonius (1980) found a lower error rate with dark letters on a white background.

How Nova Reduces Glare and Reflection with Contrast Enhancement

To reduce glare on your monitor, Nova's tinted viewport enhances the contrast between the screen and reflections from surrounding light. That light passes through the viewport and bounces off the surface of the screen. It then passes back through the viewport. Each time the light passes through the glass, 55 percent is absorbed. Light from the monitor passes through the viewport only once. The result gives you a two-to-one contrast enhancement ratio.

To check the effect of Nova's contrast enhancement, first view the monitor through the glass. Now remove the glass so that you can view the monitor directly. You'll see a dramatic difference.

CDAR Anti-Reflective Coating

To further reduce unwanted viewport surface reflections, Nova offers an optional CDAR coated viewport. This multi-layer, metallic oxide coating is applied to the glass at a 30-degree bias. It's most effective at your viewing angle.

In combination with the glass that already absorbs 55 percent of the light, the CDAR coating can reduce glare up to 99.7 percent. We must remember that our eyes are extremely sensitive to light. Some light sources are so bright that even a 99.7 percent reduction will still leave reflections.

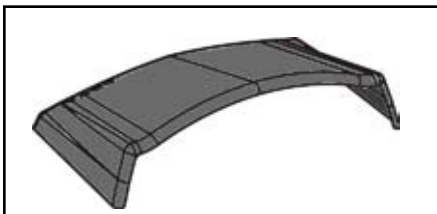
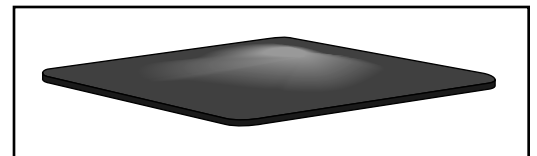

Thermoformed Visor

Sometimes it is impossible to get rid of glare source in front of a monitor. For these cases, each Nova desk comes with a thermoformed visor which will eliminate that problem. Illustration to the right shows the visor in use.

Monitor Placement

Do not place the desk close to and facing a bright, unshaded window. If you have a choice, set each monitor at a right angle to windows.

Do not place bright lights directly above the monitor or behind the user. If a light fixture reflects on the screen, remove the bulb, if possible. Often, task lamps can substitute for some of your overhead lighting.

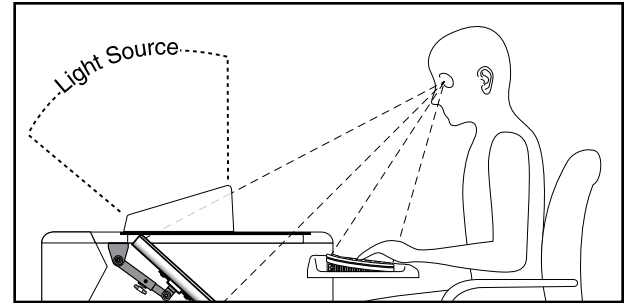

Tackle Lighting Problems Early

Nova recommends that you consult a lighting professional in the early stages of designing a work space. Too often, lighting is an afterthought. If you address lighting early in the project, you can avoid problems.

“Solving the Problem of VDT Reflections” (Rea 1991) outlines solutions for lighting problems in computerized offices.

How To Adjust Your Monitor

The Monitor Support adjusts three ways: for height, angle and forward/backward. Adjust it so that you have a comfortable viewing angle of the monitor when you are in a normal working position.

- 1. Install monitor as high as possible without raising glass.**
- 2. Screen should point slightly above the user's face bottom edge of monitor is nearer to the eye than top edge.**
- 3. Preferred position: top edge of monitor is at back edge of glass.**

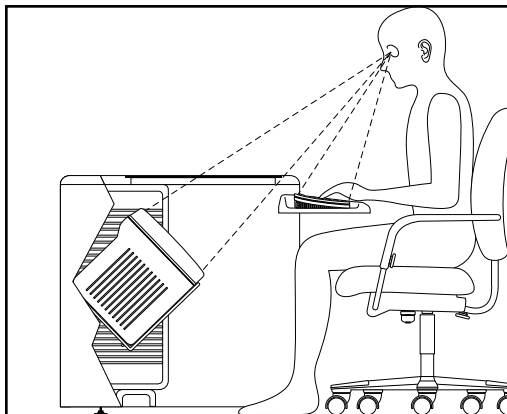
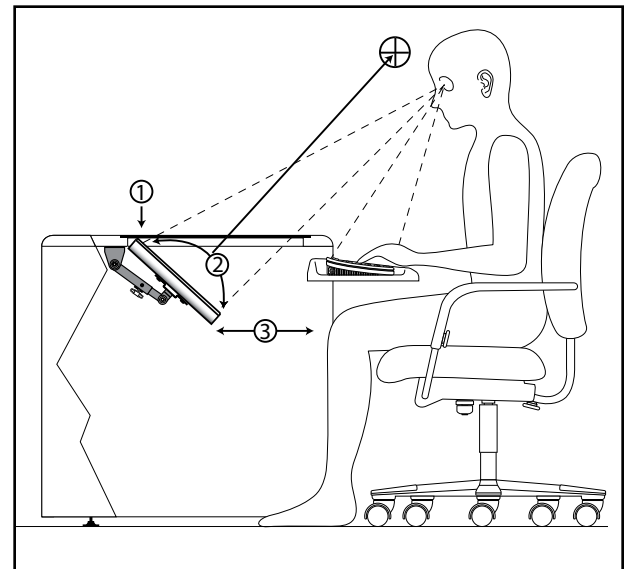

Too Low!
...Monitor is located too far below glass so that view is obstructed.

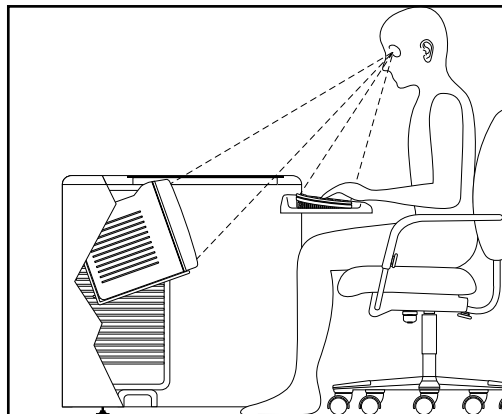

Wrong Angle!
...Top of monitor is closer to the eye than bottom of the monitor.

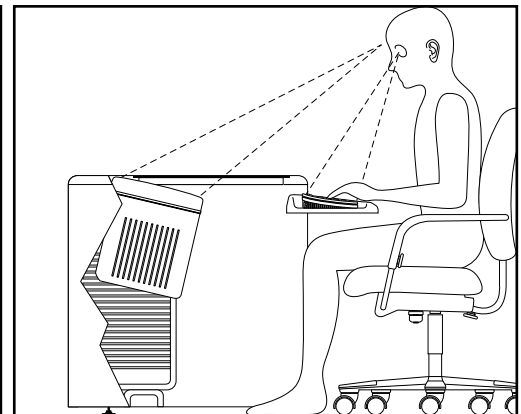

Wrong Angle!
...Monitor is angled too far upwards – angle is too extreme.

Nova Solutions Continue Beyond Ergonomics

Nova offers further advantages not found with other computer furniture:

Saves space - Nova removes the CPU, monitor and keyboard and frees up the most critical part of your workspace.

Manages wires - Nova hides unsightly computer cables. This also keeps them from being accidentally disconnected.

Assures privacy - The recessed monitor provides security for sensitive materials.

Lowers costs - Nova eliminates the need for a separate computer workstation. This saves office space.

Enhances eye contact - Nova allows a direct line of sight.

References

- Anderson, T.J. et al., 1987, Carpal Tunnel Syndrome- Selected References, National Institute for Occupational Safety and Health.
- Ankrum, D.R., 1996, Viewing Distance at Computer Workstations. *Workplace Ergonomics*. 2, 5, 10-13.
- Ankrum, D.R., 1997, A challenge to eye-level, perpendicular-to-gaze, monitor placement. *Proceedings of the 13th Triennial Congress of the International Ergonomics Association*, Vol. 5, p. 35-37. Helsinki: Finish Institute of Occupational Health.
- Ankrum, D.R., Hansen, E.E., and Nemeth, K.J., 1995, The vertical horopter and the angle of view. In A. Grieco, G. Molteni, B. Piccoli and E. Occhipinti (eds.), *Work with Display Units '94*. Amsterdam: Elsevier.
- Ankrum, D.R. and Nemeth, K.J., 1995, April, Posture, Comfort and Monitor Placement. *Ergonomics in Design*, p. 7-9.
- Bielschowsky, A., 1940, *Lectures on Motor Anomalies*. Dartmouth Publications. Hanover, p.27.
- Boorish, I.M., 1970, *Clinical Refraction*. The Professional Press, Chicago, p. 180.
- Burde, R., Feldon, E., 1987, The extraocular muscles: Anatomy, physiology, and pharmacology. *Adler's Physiology of the Eye*. CV Mosby, St. Louis, p. 95.
- Bureau of Labor Statistics, U.S. Department of Labor, 1993, *Survey of Occupational Injuries and Illnesses in the U.S.*
- Chaffin, D.B., 1973, Localized Muscle Fatigue - Definition and Measurement. *Journal of Occupational Medicine*, 15, 4, 346-354.
- Chaffin, D.B., 1991, *Occupational Biomechanics*. Wiley-Interscience, New York, p. 401.
- Chatterjee, D.S., 1987, Repetition strain injury - a recent review. *Journal of the Society of Occupational Medicine*, 37, 100-105.
- Collins, C.C., et al, 1975, Muscle strain during unrestrained human eye movements. *Journal of Physiology*, London, 245, 351-369.

- Dainoff, M.H., Dainoff, M.J., 1986, People and Productivity. Holt, Rinehart and Winston of Canada, Ltd., Toronto, p. 23-26.
- Duke - Elder, S., Wybar, K., 1973, Ocular Motility and strabismus. System of Ophthalmology. Henry Kimpton, London, Vol. 6, p. 100.
- Ehrlich, D.L., 1987, Near Vision Stress: Vergence Adaption and Accommodative Fatigue. Ophthalmology and Physiological Optics, 7, 4, p. 353-357.
- Fisher, R.F., 1977, The force of contraction of the human ciliary muscle during accommodation. Journal of Physiology, London, 270, 51-74.
- Grandjean, E., 1987, Ergonomics in Computerized Offices. Taylor & Francis, London, p. 21, 143.
- Grandjean, E., et al., 1983, VDT workstation design: preferred settings and their effects. Human Factors, 25, 161-175.
- Gunnarsson, E. and Soderberg, I., 1979, Work at a VDT Presenting Textural Information at a Publishing Company: An Inventory of Visual Ergonomic Problems. AMMF, National Board of Occupational Safety and Health, Stockholm. p. 21.
- Helmholtz, H., 1962, Helmholtz's Treatise on Physiological Optics. Dover, New York, Vol. 3, pp. 44-45.
- Heuer, H., Owens, D., 1989, Vertical gaze direction and the resting posture of the eyes. Perception, 18, 363-377.
- Hill, S.G., Kroemer, K.H.E., 1986, Preferred Declination of the Line of Sight. Human Factors, 28, 127-134.
- Human Factors Society, 1988, American National Standard for Human Factors Engineering of Visual Display Terminal Workstations (ANSI HFS-100). San Jose, CA; Human Factors Society.
- Jampel, R., Shi, D., 1992, The Primary Position of the Eyes, The Resetting Saccade, and the Transverse Visual Head Plane. Investigative Ophthalmology & Visual Science, 33, 8, 2501-2510.
- Jaschinski-Kruza, W., 1988, Visual strain during VDU work: the effect of viewing distance and dark focus. Ergonomics, 31, 10, 1449-1465.
- Jaschinski-Kruza, W., 1990, On the preferred viewing distances to screen and document at VDU workplaces. Ergonomics, 33, 8, 1055-1063.
- Jaschinski-Kruza, W., 1991, Eyestrain in VDU Users: Viewing Distance and the Resting Position of Ocular Muscles. Human Factors, 33, 1, 69-83.
- Kaufman, P.L., 1992, Accommodation and Presbyopia: Neuromuscular and Biophysical Aspects. Adler's Physiology of the Eye. C.V. Mosby, St. Louis, p. 391-411.
- Krimsky, E., 1948, The Management of Binocular Imbalance. Lea and Febiger, Philadelphia, p. 101.

- Kroemer, K., 1989, Cumulative trauma disorders: Their recognition and ergonomics measures to avoid them. *Applied Ergonomics*, 20, 4, 274-280.
- Krueger, H., 1984, *Visual Functions in Offices - Including VDUs (Introductory paper.) Ergonomics and Health in Modern Offices.* Taylor & Francis, London.
- Lee, K., Swanson, N., Sauter, S., Wickstrom, R., Waikar, A., and Mangum, M., 1992, A review of physical exercises recommended for VDT operators., *Applied Ergonomics*, 25, 6, 387-408.
- Moses, R., 1975, Accommodation. *Adler's Physiology of the Eye.* CV Mosby, St. Louis. p. 305.
- Owens, D.A., 1984, The resting state of the eyes. *American Scientist*, 72, 378-387.
- Owens, D.A., Wolf-Kelly, K., 1987, Near Work, Visual Fatigue, and Variations of Oculomotor Tonus. *Investigative Ophthalmology and Visual Science*, 28, 743-749.
- Rea, M.S., 1991, Solving the Problem of VDT Reflections. *Progressive Architecture*, Oct. p. 35-40.
- Ripple, P., 1952, Variation of Accommodation in Vertical Directions of Gaze. *American Journal of Ophthalmology*, 35, 1630-1634.
- Rupp, B.A., 1987, Personal communication.
- Scobee, R.G., 1952, The Oculorotary Muscles. CV Mosby, St. Louis, p. 60, 117-118.
- Sheedy, J.E., ed., 1990, *Video Display Terminals: Solving the Vision Problems, Optometry-Environmental Optics.* Vol. 2, J.B. Lippincott, Philadelphia. P. 1-16.
- Sheedy, J.E., 1992, Vision Problems at Visual Display Terminals: A Survey of Optometrists. *Journal of The American Optometrist Association*, 63, 687-692.
- Sotoyama, M. Abe, S., Jonai, H., Villanueva, M.B.G.; and Saito, S. (1997). Improvement in visual comfort of VDT workers from the aspects of vertical gaze direction and tear volume. *Proceedings of the 13th Triennial Congress of the International Ergonomics Association, 1997.* Vol. 5, p. 59-61. Helsinki: Finish Institute of Occupational Health.
- Tychsen, L., 1992, Binocular Vision, *Adler's Physiology of the Eye.* C.V. Mosby, St. Louis, p. 773-853.
- Tsubota, K., Nakamori, K., 1993, Dry Eyes and Video Display Terminals. *New England Journal of Medicine*, 328, 8, 584.
- Tyrrell, R., Leibowitz, H., 1990, The Relation of Vergence Effort to Reports of Visual Fatigue Following Prolonged Near Work. *Human Factors*, 32, 3, 341-357.

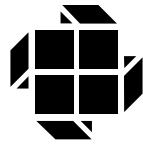

NOVA[®]
The Right Solutions

NOVA Solutions, Inc.

421 W. Industrial Avenue

Effingham, IL 62401

Phone: 800-730-6682

Fax: 800-940-6682

www.novadesk.com

info@novasolutionsinc.com