



NOVA[®]
The Natural Solution™

The Natural Way to Look at a Computer™

Retrofit Kit Assembly Instructions

Model #

50-0-2124

-24, -30, -33, -34

Step 1

If the worksurface is prepared for Retrofit Kit & Keyboard Drawer Installation, skip to Step 3. Otherwise, please prepare your worksurface to the specifications shown in Figure 1a for Viewport & Side Assembly milling/drilling.

The retrofit kit can be installed in almost any work surface. The kit is designed to attach to a work surface that is 1-1/8" to 2" in thickness. Thinner work surfaces may require some build-up of material for proper installation. Glass work surfaces are not recommended. If your countertop is a solid material such as natural granite or marble or a fabricated solid surface such as Corian, you should use a professional fabricator to create the opening and surface mounting anchors required for your kit. Forward a copy of the boring pattern and hole size cut out to a professional fabricator.

FIGURE 1a

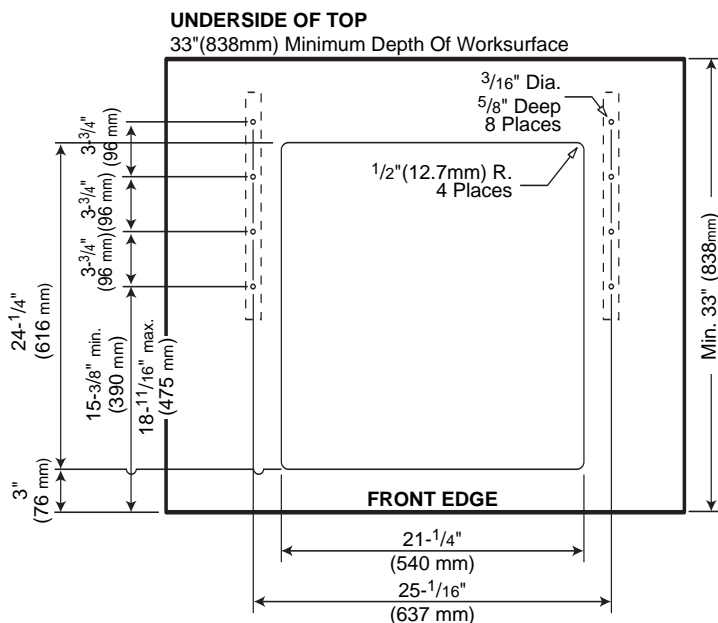

ASSEMBLED VIEW

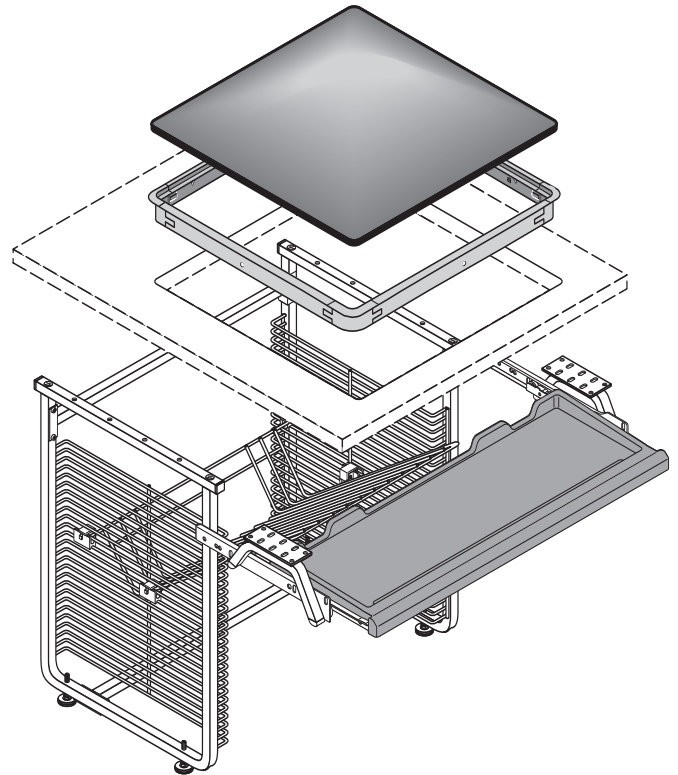

Step 2

Keyboard Drawer holes (as shown in Figure 1b) should be drilled for the specific keyboard size. Care must be exercised to use the specifications in Figure 1b regarding drill size and hole depth.

To offset viewport and keyboard drawer, please call customer support at 1-800-730-6682 for special instructions.

FIGURE 1b

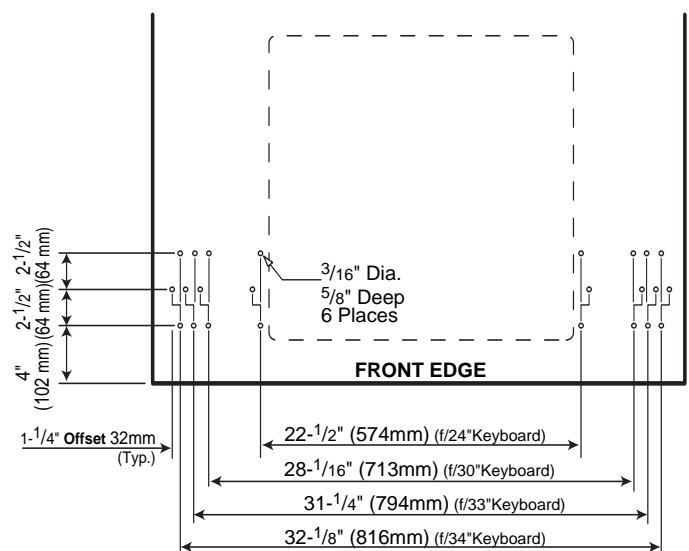

HARDWARE

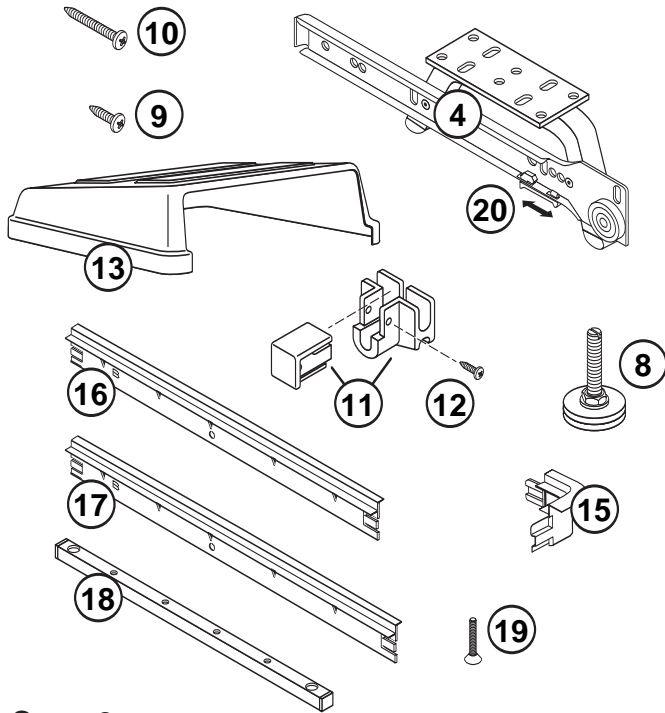

Step 3

Review and identify Retrofit Kit parts listed above.

Step 4

Attach Cross Braces (Ref. #3) to Side Assemblies (Ref. #2) using eight (8) Screws (Ref. #9). Attach Top Rails (Ref. #18) using four (4) Top Rail Screws (Ref. #19). See Figure 2.

FIGURE 2

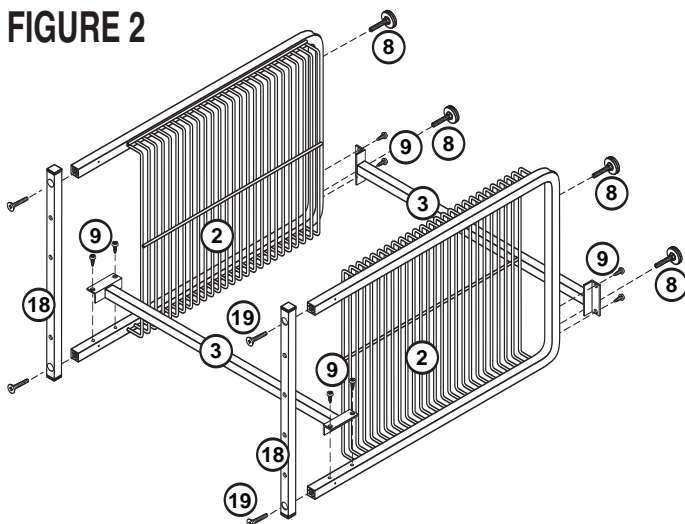

PACKING LIST

Ref. #	Item #	Qty.	Description
1	20060126	1	Keyboard hanger with glide – Left
2	5002121SA	2	Side Assembly
3	20060104	2	Cross Brace
4	20060127	1	Keyboard hanger with glide – Right
5	Varies with Retrofit	1	Keyboard Drawer
6	20060116	1	Monitor Support
7	5081073	1	Viewport Glass
8	50900258	4	Leveler
9	1412APPBO	12	Screw - #14x3/4"
10	50900032	10	Screw - #14x1-1/2"
11	TB-M	4	Tracking Block
	TB-F	4	Tracking Block
12	6N50TXPZ	8	Screw - Security, #6x5/8"
13	5081062	1	Visor
15	50900034	4	Trim Ring Corner
16	50900037	2	Trim Ring Straight C
17	50900038	2	Trim Ring Straight D
18	5002121-01	2	Top Rail
19	5002121-02	4	Threaded Screw - Top Rail
20	FR2020/Clip	2	Locking Tab
OPTIONS			
	5081120	1	Power Strip
	5081066	1	CPU Holder
	5081023	1	Anti-Reflective Glass

Step 5

Insert Levelers (Ref. #8) into bottom of Side Assembly (Ref. #2). See Figure 2.

Step 6

Turn Retrofit Assembly upright. Slide under viewport cutout in worksurface. Align holes in top rails of Side Assemblies (Ref. #2) with holes in worksurface. Attach Retrofit Assembly to the worksurface securely using eight (8) Screws (Ref. #10). Optional: Adjust Levelers (Ref. #8).

Step 7

As shown in Figure 3, attach Left Keyboard Hanger securely to the underside of the worksurface using two (2) Screws (Ref. #9) and one (1) Screw (Ref. #10). Repeat procedure for other side.

FIGURE 3

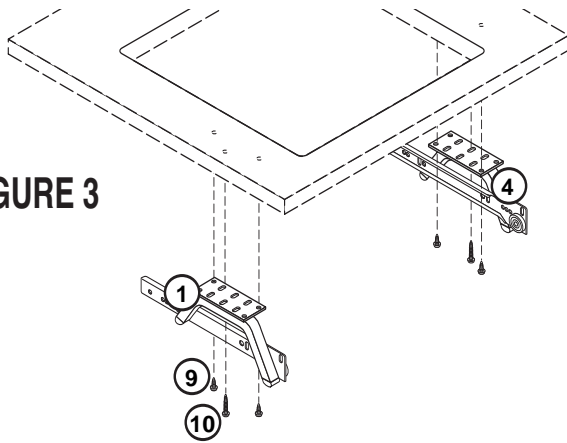

IMPORTANT: The longer of the screws (Ref. #10) passes through the tubular section of the Keyboard Hanger allowing the assembly to be leveled by either tightening or loosening the screw. Adjusting the screws allows you to fine-tune the action of the keyboard drawer.

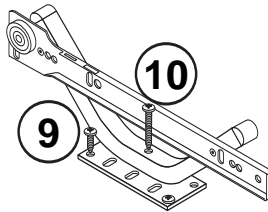

EXPLODED VIEW

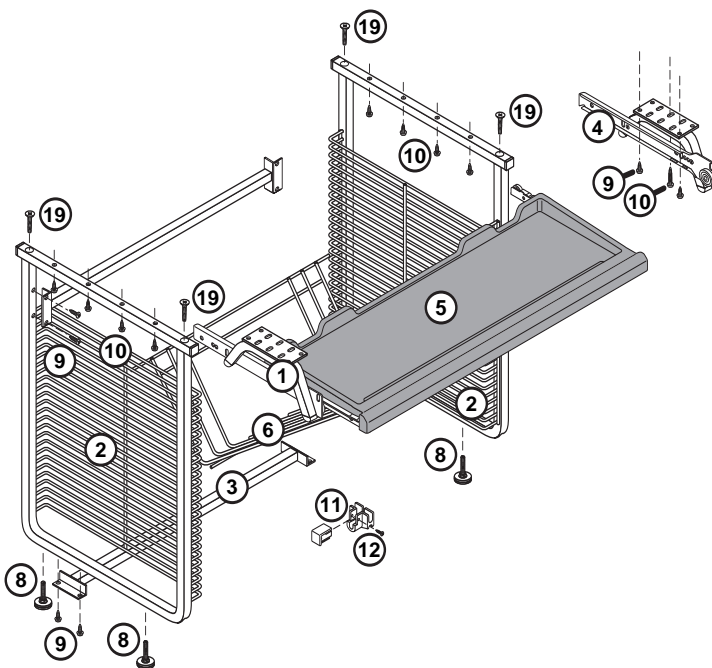

Step 8

After installing the Keyboard Drawer, pull Outward Locking Tab forward to lock in place. See Figure 4.

FIGURE 4

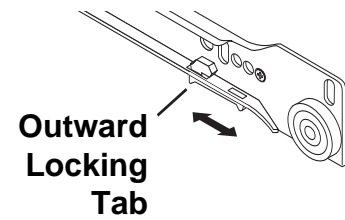

Step 9

Install Trim Ring by snapping pieces together (Ref. #15, 16 and 17), lowering into cutout, and attaching with four (4) screws (Ref. #12).

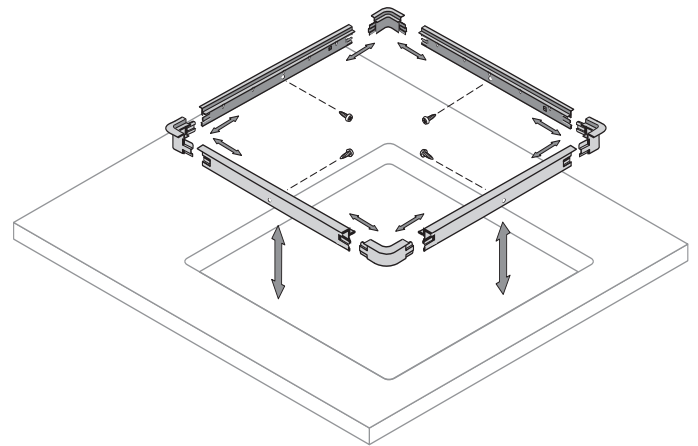

Step 10.1

Adjusting Your Monitor: The Monitor Support adjusts three ways — height (up/down), angle, and forward/backward. Adjust it so that you have a comfortable viewing angle of the monitor when you're in a normal working position. Push Outward Locking Tabs back to unlock keyboard drawer. See Figure 4. Remove the keyboard drawer and the glass. Lower the monitor through the viewport opening while allowing the wires to feed through the back of the monitor support. If the monitor is too heavy, make sure you get assistance.

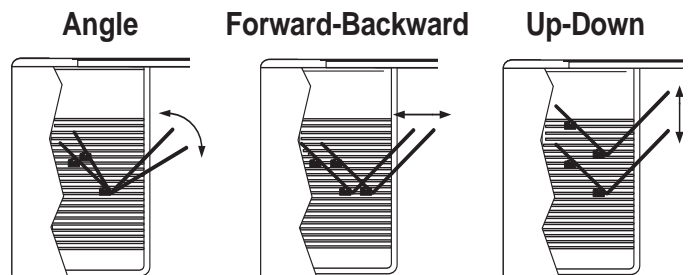

Monitor Adjustment

Maximum Monitor Dimensions:
23-1/2"D x 20-1/8"W x 19"H

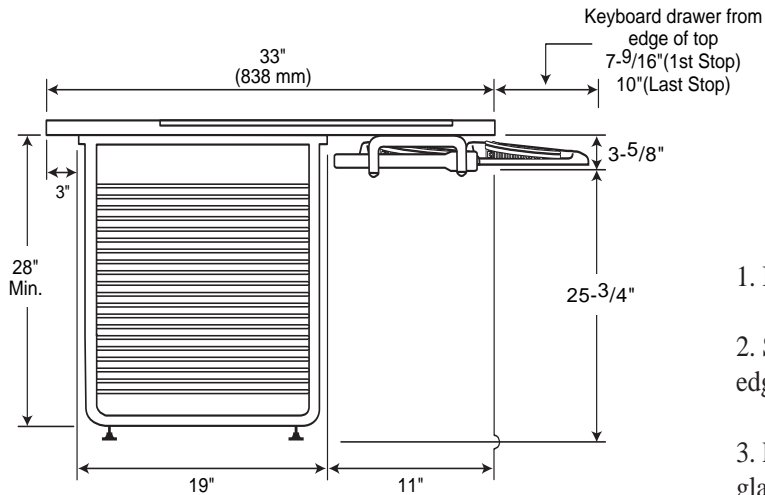
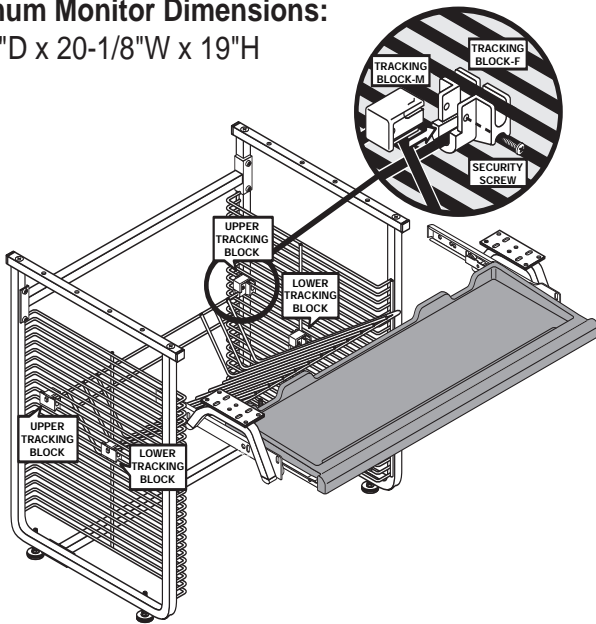

Step 10.2

Determine the modification necessary to accomplish the preferred viewing angle. To make angle adjustments, move either the top or the bottom Tracking Block assemblies independently of each other. For oversized monitors, a good starting point is 7 spaces up in front and 6 spaces up in back.

Step 10.3

Once the angle is adjusted, adjust the height by raising or lowering both upper and lower Tracking Block assemblies the same number of spaces.

Step 10.4

After you achieve the desired height and angle, you can fine tune the viewing distance by sliding the carriage forward and backward. Each time you make an adjustment, reinsert the Male Tracking Blocks. When the adjustment is completed, install the Security Screws. *The bottom of the screen should always be closer to your eyes than the top.*

Downward Gaze™ Monitor Installation

Correct Installation

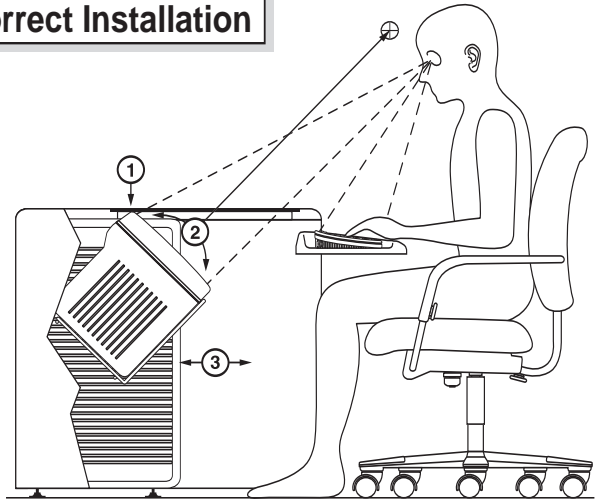

1. Install monitor as high as possible without raising glass.
2. Screen should point slightly above user's face (bottom edge of monitor is nearer to the eye than top edge).
3. Preferred position: top edge of monitor is at back edge of glass.

Incorrect Installation

Wrong Angle!
...Top of monitor is closer to the eye than the bottom of the monitor.

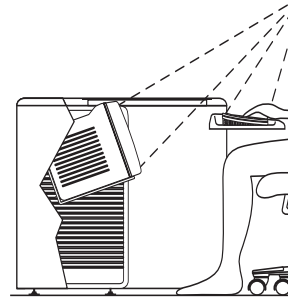

Too Low!
...Monitor is located too far below glass so that view is obstructed.

