



NOVA[®]

The Natural Solution™

The natural way to look at a computer™

Flat Panel Display Arm Retrofit Kit Assembly Instructions

Model #

FPA-0-2124

-24, -27, -28, -30, -33, -34

The arm ships with two VESA plates. Determine the one you need by holding VESA plates up to the attachment holes on the back of the monitor. Select the one where all four holes line up with the VESA plate holes.

Step 1.

Cut opening for viewport. (Figure 1A). Prepare surface for keyboard drawer (Figure 1B).

Step 2.

Using the desk bracket (B) as a template, locate and drill bracket holes (Figure 1A). Note drill size and hole depth!

Figure 1A

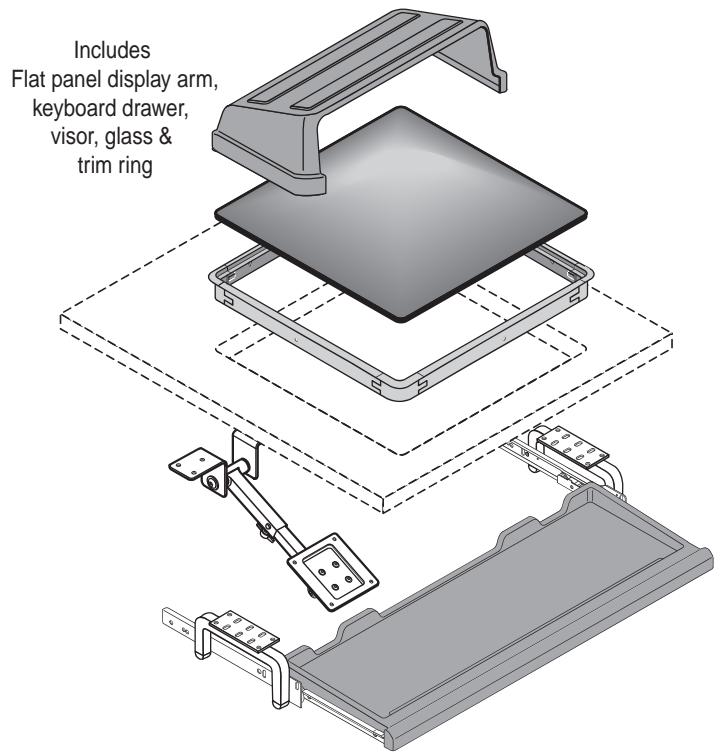
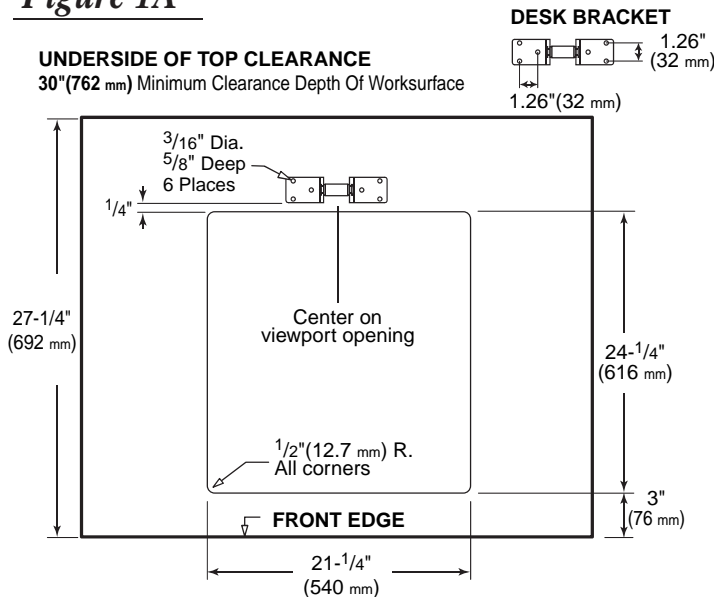
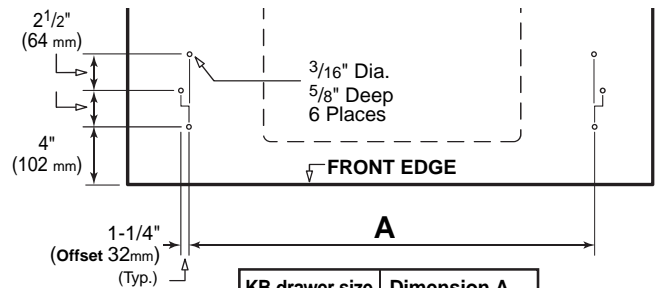

Figure 1B - Hole pattern for keyboard drawer



KB drawer size	Dimension A
24"	22 ¹⁹ / ₃₂ " (574 mm)
27"	25 ⁵ / ₁₆ " (643 mm)
28"	26 ¹ / ₈ " (664 mm)
30"	28 ¹ / ₁₆ " (713 mm)
33"	31 ¹ / ₄ " (794 mm)
34"	32 ¹ / ₈ " (816 mm)

PACKING LIST

QTY	REF #	ITEM #	DESCRIPTION
1	A1		75 mm *VESA plate
1	A2	FPA-8-2006	100 mm *VESA plate
1	B		Desk bracket
1	C	924B-2520-0-50A	Wing nut
10	D	1412APPBO	Screw, #14 x 3/4"
4	E	50900219	Screw, 4mm
1	F	20060126	Keyboard hanger w/ glide - left
1	G	20060127	Keyboard hanger w/ glide - right
1	H	Varies	Keyboard drawer
1	J	5081073	Viewport glass
2	L	50900032	Screw - #14 x 1-1/2"
4	M	6N50TXPZ	Security screw #6 x 5/8"
4	N	50900034	Trim ring corner
2	O1	50900037	18" Trim ring straight (C)
2	O2	50900038	21" Trim ring straight (D)
1	P	5081062	Visor
2	Q	FR2121/Clip	Locking tab
4	S	28859	Screw, 8-32 x 1/4"

*VESA 75/100 Standard

Step 3.

Align holes in desk mounting bracket(B) with holes in worksurface (Figure 2). Attach using screws (D).
WARNING: Removing the set screws or oiling the joints could cause the flat panel display to fall and void the warranty.

Figure 2

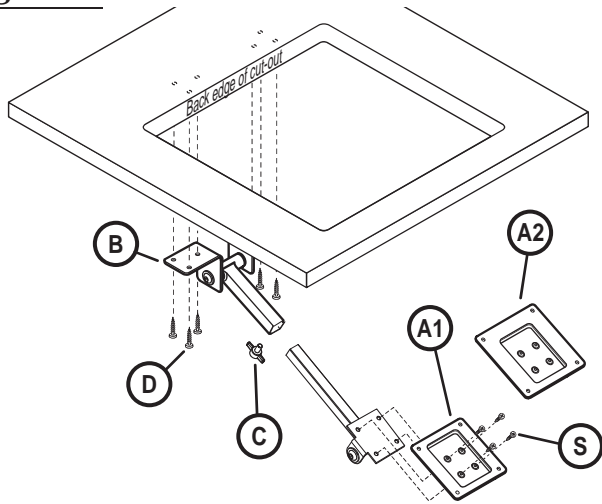

Step 4. Attach flat panel display to VESA plate

Remove flat panel display base. Attach flat panel display to VESA plate with screws (E, Figure 3). Depress silver spring pin on VESA plate extension tube and slide it into the desk mount extension tube. Tighten wing nut (C, Figure 4). See "Monitor Angle" for adjustment guidance. When installing some Apple® flat panel displays, a VESA Adapter (Model #50-8-4100) may be necessary. Contact Customer Support for more information.

Figure 3

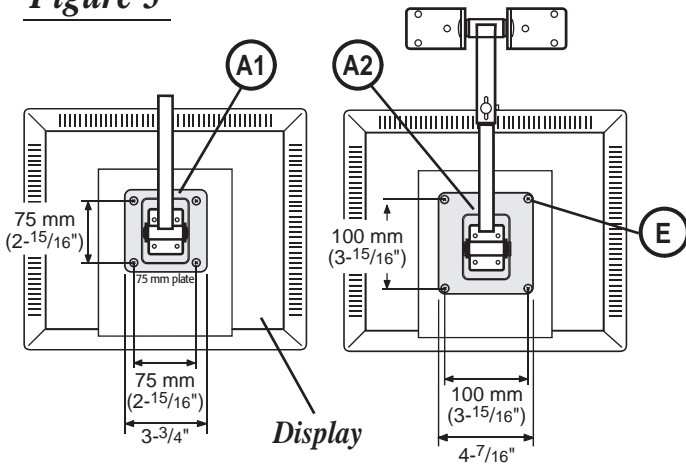
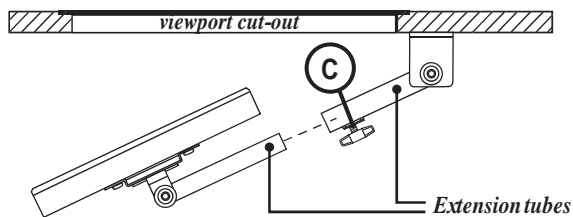

Figure 4



Step 5.

Attach keyboard hangers (F,G, Figure 5) to underside of worksurface with screws (D, E). Insert outward locking tab (Q) by pulling it forward to lock in place.

IMPORTANT: The longer screws (L) pass through the tubular section of the keyboard hanger. That allows the assembly to be leveled by loosening or tightening the screws.

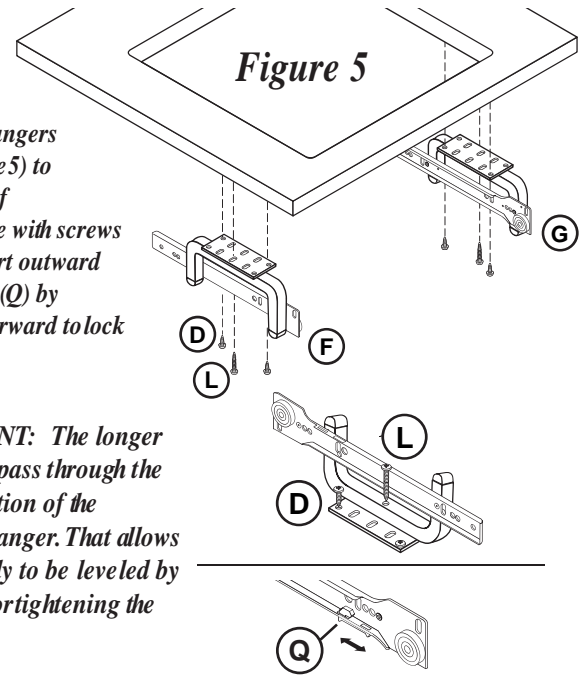

Step 6. Install trim ring & viewport glass

Snap trim ring pieces (N, O1 & O2) together. Insert into viewport cutout and attach with screws (M). Carefully insert viewport glass into trim ring. Slide keyboard tray into glides.

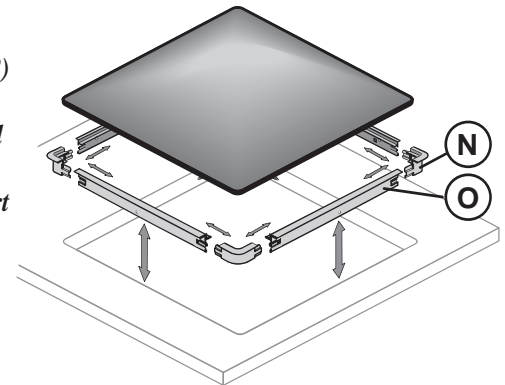

Monitor angle

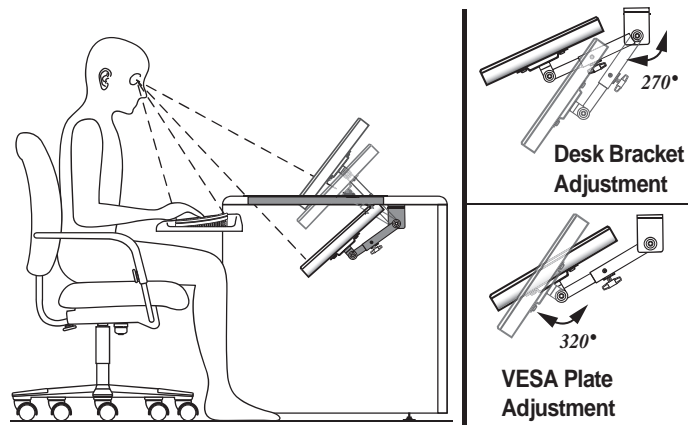

1. Locate screen as high as possible without raising glass.
2. Aim screen slightly above user's eyes. (Bottom of screen should be closer to eyes than top of screen.)
3. Preferred location is with top edge of flat panel display at back edge of glass.
4. For semi-recessed positions, remove viewport glass and raise flat panel display.